**Optics and photonics —
Environmental test methods —**

**Part 7:
Resistance to drip or rain**

*Optique et photonique — Méthodes d'essais environnementales —
Partie 7: Résistance au ruissellement ou à la pluie*





COPYRIGHT PROTECTED DOCUMENT

© ISO 2015

All rights reserved. Unless otherwise specified, no part of this publication may be reproduced or utilized otherwise in any form or by any means, electronic or mechanical, including photocopying, or posting on the internet or an intranet, without prior written permission. Permission can be requested from either ISO at the address below or ISO's member body in the country of the requester.

ISO copyright office
Case postale 56 • CH-1211 Geneva 20
Tel. + 41 22 749 01 11
Fax + 41 22 749 09 47
E-mail copyright@iso.org
Web www.iso.org

Published in Switzerland

Contents

	Page
Foreword	iv
Introduction	vi
1 Scope	1
2 Normative references	1
3 General information and test conditions	1
4 Conditioning	1
4.1 Conditioning method 72: Drip.....	1
4.2 Conditioning method 73: Steady rain.....	2
4.3 Conditioning method 74: Driving rain.....	2
5 Procedure	2
5.1 General.....	2
5.2 Preconditioning.....	2
5.3 Recovery.....	2
5.4 Final test.....	2
6 Environmental test code	3
7 Specification	8
Annex A (informative) Explanatory notes	9

Foreword

ISO (the International Organization for Standardization) is a worldwide federation of national standards bodies (ISO member bodies). The work of preparing International Standards is normally carried out through ISO technical committees. Each member body interested in a subject for which a technical committee has been established has the right to be represented on that committee. International organizations, governmental and non-governmental, in liaison with ISO, also take part in the work. ISO collaborates closely with the International Electrotechnical Commission (IEC) on all matters of electrotechnical standardization.

The procedures used to develop this document and those intended for its further maintenance are described in the ISO/IEC Directives, Part 1. In particular the different approval criteria needed for the different types of ISO documents should be noted. This document was drafted in accordance with the editorial rules of the ISO/IEC Directives, Part 2 (see www.iso.org/directives).

Attention is drawn to the possibility that some of the elements of this document may be the subject of patent rights. ISO shall not be held responsible for identifying any or all such patent rights. Details of any patent rights identified during the development of the document will be in the Introduction and/or on the ISO list of patent declarations received (see www.iso.org/patents).

Any trade name used in this document is information given for the convenience of users and does not constitute an endorsement.

For an explanation on the meaning of ISO specific terms and expressions related to conformity assessment, as well as information about ISO's adherence to the WTO principles in the Technical Barriers to Trade (TBT) see the following URL: [Foreword - Supplementary information](#)

The committee responsible for this document is ISO/TC 172, *Optics and photonics*, Subcommittee SC 1, *Fundamental standards*.

This third edition cancels and replaces the second edition (ISO 9022-7:2005), of which it constitutes a minor revision.

ISO 9022 consists of the following parts, under the general title *Optics and photonics — Environmental test methods*:

- *Part 1: Definitions, extent of testing*
- *Part 2: Cold, heat and humidity*
- *Part 3: Mechanical stress*
- *Part 4: Salt mist*
- *Part 6: Dust*
- *Part 7: Resistance to drip or rain*
- *Part 8: High internal pressure, low internal pressure, immersion*
- *Part 9: Solar radiation and weathering*
- *Part 11: Mould growth*
- *Part 12: Contamination*
- *Part 14: Dew, hoarfrost, ice*
- *Part 17: Combined contamination, solar radiation*
- *Part 20: Humid atmosphere containing sulfur dioxide or hydrogen sulfide*

- *Part 22: Combined cold, dry heat or temperature change with bump or random vibration*
- *Part 23: Low pressure combined with cold, ambient temperature and dry and damp heat*

Introduction

Optical instruments are affected during their use by a number of different environmental parameters which they are required to resist without significant reduction in performance and to remain within defined specifications.

The type and severity of these parameters depend on the conditions of use of the instrument (for example, in the laboratory or workshop) and on its geographical location. The environmental effects on optical instrument performance in the tropics and subtropics are totally different from those found when they are used in arctic regions. Individual parameters cause a variety of different and overlapping effects on instrument performance.

The manufacturer attempts to ensure, and the user naturally expects, that instruments will resist the likely rigours of their environment throughout their life. This expectation can be assessed by exposure of the instrument to a range of simulated environmental parameters under controlled laboratory conditions. The severity of these conditions is often increased to obtain meaningful results in a relatively short period of time.

In order to allow assessment and comparison of the response of optical instruments to appropriate environmental conditions, ISO 9022 contains details of a number of laboratory tests which reliably simulate a variety of different environments. The tests are based largely on IEC standards, modified where necessary to take into account features special to optical instruments.

As a result of continuous progress in all fields, optical instruments are no longer only precision-engineered optical products, but, depending on their range of application, also contain additional assemblies from other fields. For this reason, the principal function of the instrument is to be assessed to determine which International Standard should be used for testing. If the optical function is of primary importance, then ISO 9022 is applicable, but if other functions take precedence, then the appropriate International Standard in the field concerned should be applied. Cases can arise where application of both ISO 9022 and other appropriate International Standards will be necessary.

.....

Optics and photonics — Environmental test methods —

Part 7: Resistance to drip or rain

1 Scope

This part of ISO 9022 specifies the methods relating to the environmental tests of optical instruments including additional assemblies from other fields (e.g. mechanical, chemical, and electronic devices), under equivalent conditions, for their ability to resist the influence of drip or rain.

The purpose of testing is to investigate to what extent the optical, climatic, mechanical, chemical, and electrical (including electrostatic) performance characteristics of the specimen are affected by drip or rain. Contamination of drip or rain water due to impurities in the air is to be ignored for the purposes of this part of ISO 9022.

2 Normative references

The following documents, in whole or in part, are normatively referenced in this document and are indispensable for its application. For dated references, only the edition cited applies. For undated references, the latest edition of the referenced document (including any amendments) applies.

ISO 9022-1, *Optics and photonics — Environmental test methods — Part 1: Definitions, extent of testing*

3 General information and test conditions

At the beginning of exposure, the temperature of the water shall be below that of the specimen. During exposure, the specimen shall be mounted in the possible operating positions on a rotary table which rotates at a speed of 1 r/min to 2 r/min about its axis perpendicular to the sprinkling area. Prior to testing, the required rain or drip rate shall be measured and set in the centre of the sprinkling area occupied by the specimen.

Measurement of the rain rate or drip rate shall be performed using the Hellman rain gauge (see [A.3](#)). If various measuring areas exist and/or several measurements are performed, the mean value for all measurements shall lie within the limits specified in [Table 1](#), [Table 2](#), and [Table 3](#) for the required rain rates.

4 Conditioning

4.1 Conditioning method 72: Drip

The drip shall be produced with the test apparatus shown in [Figure 1](#). This size of the test apparatus and the dispenser plate (see [Figure 2](#)) shall be determined by the size of the specimens. Specimens requiring a dispenser plate of more than 1 m² may be tested in sections. The required water level above the dispenser plate shall be regulated by a float valve and/or overflows (see [Figure 1](#)). Decalcified or fully desalted water shall be used to prevent blockage of the fine holes in the dispenser plate. The distance between the specimen and the dispenser plate shall not be less than 1 m. Care shall be taken to ensure that every point of the possible upper sides of the specimen are exposed to the drip during the test.

4.2 Conditioning method 73: Steady rain

The test shall be performed with tap water (drinking water) or with water prepared in accordance with [4.1](#). The shower heads used shall correspond to those shown in [Figure 3](#). The swivelling shower heads shall be arranged in such a way that the required rainfall rate is evenly distributed over the sprinkling area. The measurement of the rain rate shall be performed in accordance with [Clause 3](#). The number of shower heads depends upon the size of the specimen. The shower heads shall be positioned at least 2 m above the highest surface of the specimen. A recommended arrangement of the shower heads is given in [Annex A](#).

4.3 Conditioning method 74: Driving rain

The requirements of [4.2](#) shall apply for producing the rainfall. The wind generator shall be arranged so that the rain falls as evenly as possible on the specimen.

During the exposure, the rotary table bearing the specimen shall be erected approximately 2 m in the direction of the wind behind the centre of the sprinkled area which would be formed if no wind were applied.

Prior to insertion of the specimen in the test apparatus, the wind velocity and the rain rate shall be measured in the area where the centre of the specimen will be located during exposure. A rain-catching metal sheet as shown in [Figure 4](#) shall be inserted in the Hellman rain gauge.

5 Procedure

5.1 General

The test shall be conducted in accordance with the requirements of the relevant specification and with ISO 9022-1.

5.2 Preconditioning

If not specified in the relevant specification, the surface of the specimen shall be properly cleaned prior to exposure. To this end, only such neutral cleaning agents shall be used that do not leave a film on or attack the surface of the specimen. After cleaning, the specimen shall be restored to service condition (e.g. by the application of protective grease).

5.3 Recovery

If not specified in the relevant specification, the surface of the specimen shall be dried. Blowing with compressed air is not permitted. The temperature shall then be adjusted to ambient conditions.

5.4 Final test

After recovery, internal optical surfaces of the specimen might show a moisture film. This shall disappear in the time specified in the relevant specification.

In the event that penetrated water cannot be detected by visual inspection, a method of examining whether moisture has penetrated shall be specified in the relevant specification.

6 Environmental test code

The environmental test code shall be as defined in ISO 9022-1, giving a reference to ISO 9022 and the codes for the conditioning method chosen, the degree of severity, and the state of operation.

EXAMPLE The environmental test of optical instruments for resistance to steady rain, conditioning method 73, degree of severity 01, state of operation 1, is identified as:

Environmental test ISO 9022-73-01-1

Table 1 — Degrees of severity for conditioning method 72: Drip

Degree of severity		01	02	03	04	05	06	07	08	09	
Specimen temperature at beginning of exposure	°C	15 to 35									
Difference between specimen and water temperature at beginning of exposure	K	2 to 20									
Water level above dispenser plate	mm	10			40			75			
Drip rate	mm/min	1,5 ± 0,5			3,5 ± 1			5,5 ± 1			
Exposure time	min	1	5	15	5	15	30	5	15	30	
State of operation		0 or 1 or 2									
NOTE For testing with degrees of severity 01 to 06, the test apparatus is to be filled prior to exposure in such a way that the water drips evenly from each hole. The water level is to be lowered to the required volume (e.g. by opening the overflow) only after this has been guaranteed. The use of surface-active agents is not permitted.											

Table 2 — Degrees of severity for conditioning method 73: Steady rain

Degree of severity		01	02
Specimen temperature at beginning of exposure	°C	15 to 35	15 to 35
Difference between specimen and water temperature at beginning of exposure	K	2 to 20	2 to 20
Rain rate	mm/min	5 ± 2	20 ± 3
Exposure time	min	30 ± 2	30 ± 2
State of operation		0 or 1 or 2	

Table 3 — Degrees of severity for conditioning method 74: Driving rain

Degree of severity		01	02	03	04	05	06
Specimen temperature at beginning of exposure	°C	15 to 35					
Difference between specimen and water temperatures at beginning of exposure	K	2 to 20					
Wind velocities at specimen location	m/s	18 ± 3				33 ± 3	
Rain rate	mm/min	2 ± 1		10 ± 3		2 ± 1	
Exposure time	min	10	30	10	30	10	30
State of operation		0 or 1 or 2					
NOTE In the low rain rate required for degrees of severity 01, 02, 05, and 06, the water is not always distributed in the form of drops through the shower heads. However, this is counteracted by the strong turbulence of the water caused by the high wind velocity.							

Dimensions in millimetres

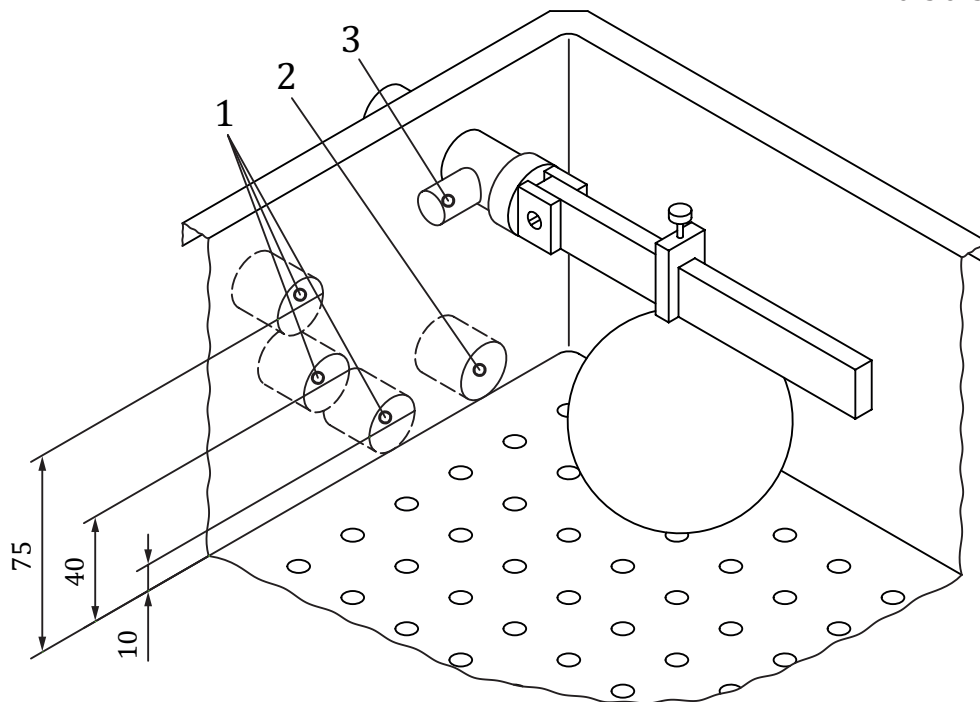

Key

- 1 overflows ($\varnothing > 20$)
- 2 outflow to empty apparatus after test
- 3 inflow

NOTE Any details not given are to be chosen appropriately.

Figure 1 — Test apparatus for drip conditioning method

Dimensions in millimetres

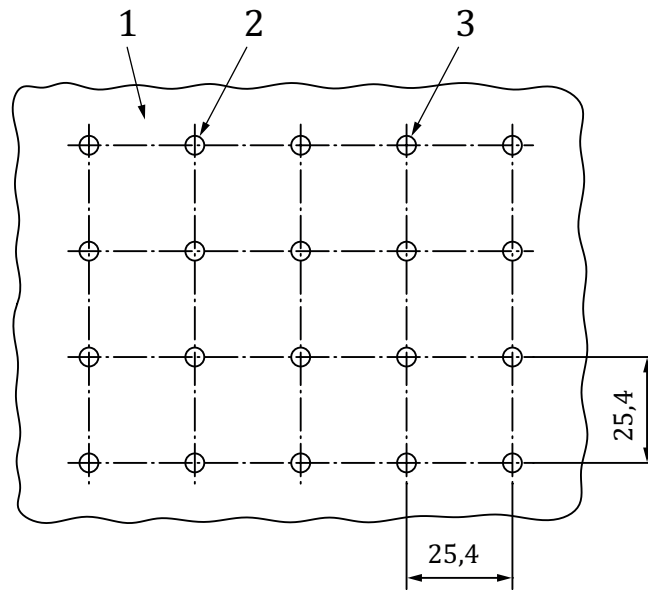
**Key**

- 1 plate made of CuZn alloy, 0,8 mm thick
- 2 holes with diameter of 0,35 mm bored through indentations in metal sheet
- 3 indentations produced with steel rod of 4,8 mm diameter, radius at tip 5 mm, pressed 1,5 mm into metal

NOTE See [Table 4](#) for dimensions and tolerances.

Figure 2 — Section of dispenser plate**Table 4 — Dimensions and tolerances for [Figure 2](#)**

Dimension mm	Tolerance mm
0,1 to 0,9	±0,02
>0,9 to 6,0	±0,1
>6,0 to 30,0	±0,2
>30,0 to 120,0	±0,3

Dimensions in millimetres

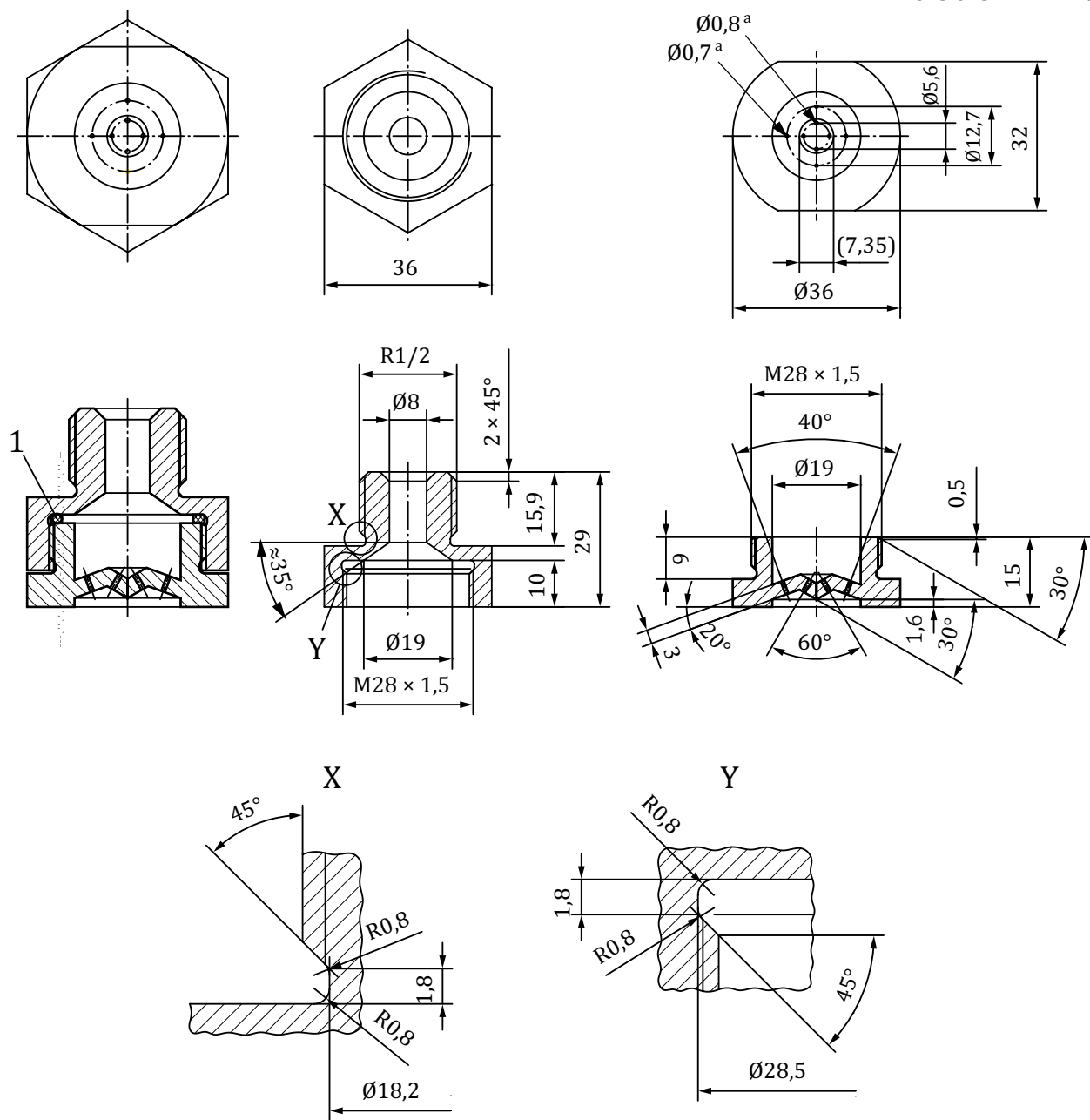

Key

- 1 O-ring or gasket
- a Holes without burr.

NOTE See [Table 5](#) for dimensions and tolerances.

Figure 3 — Shower head

Table 5 — Dimensions and tolerances for Figure 3

Dimension mm	Tolerance mm
0,1 to 0,9	$\pm 0,02$
>0,9 to 6,0	$\pm 0,1$
>6,0 to 30,0	$\pm 0,2$
>30,0 to 120,0	$\pm 0,3$
NOTE Angular tolerance is $\pm 3^\circ$.	

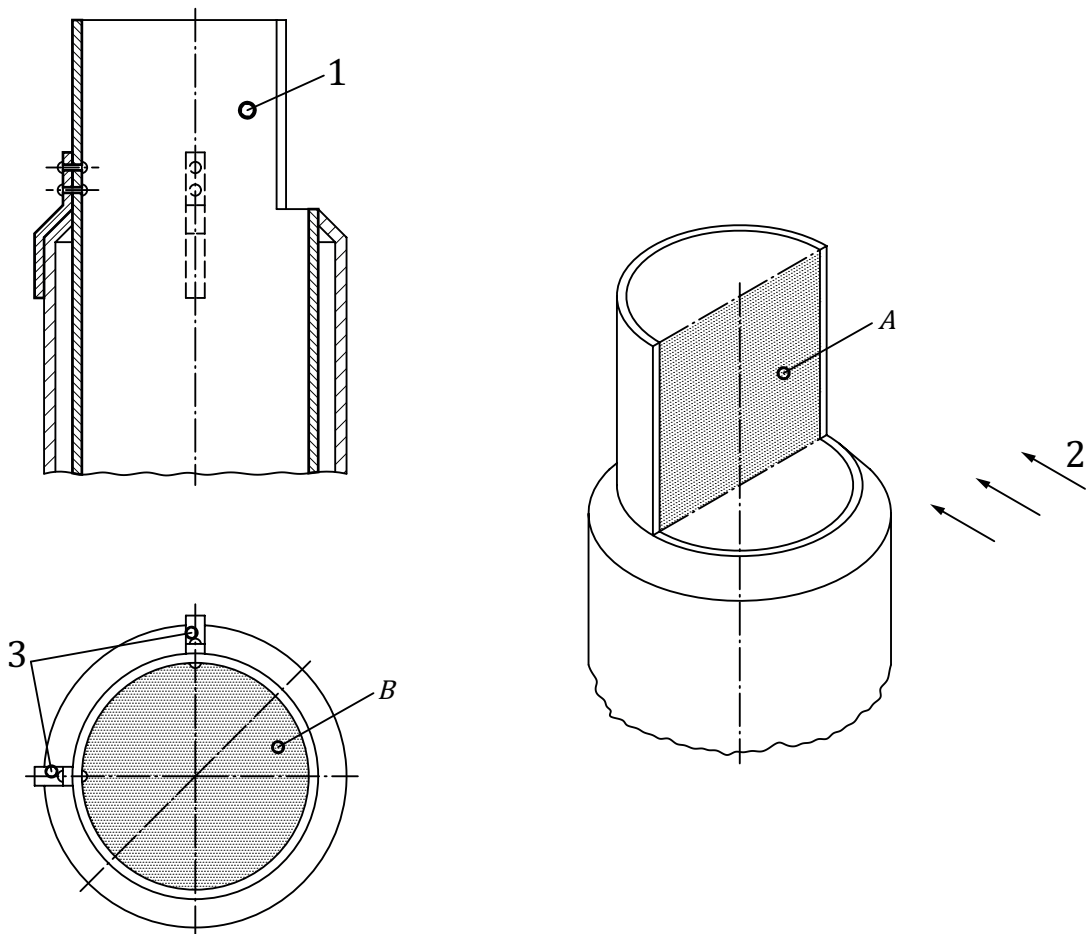

Key

- 1 rain-catching sheet for measuring rate of driving rain, inserted in the Hellmann-type rain gauge
- 2 wind direction
- 3 two additional supports necessary due to wind pressure

NOTE 1 The area of surface *A* shall be equal to the area of surface *B*.

NOTE 2 Any details not given are to be chosen appropriately.

Figure 4 — Rain-catching metal sheet

7 Specification

The equipment specification shall contain the following details:

- a) environmental test code;
- b) number of specimens;
- c) preconditioning of specimen, if other than described in [5.2](#);
- d) type and scope of initial test;
- e) state of operation 2: determination of period of operation;
- f) state of operation 2: method and scope of intermediate test;
- g) recovery, if other than described in [5.3](#);
- h) type and scope of final test, unless specified in [5.4](#);
- i) criteria for evaluation (e.g. admissible amount of penetrated water, time within which moisture film should vanish);
- j) type and scope of test report.

Annex A (informative)

Explanatory notes

A.1 General

Rain, flooding (such as that encountered on ships), water spray or splash, and the effect of dripping water are some of the manifold environmental influences to which optical instruments are exposed to during their lifetime in all states of operation. This part of ISO 9022 describes exposure to drip and rain. The ability to resist exposure to immersion and flooding can be established by ISO 9022-8.

Dripping water is used to simulate the influence on instruments of water dripping from above due to condensation or leaks. The size of the drops exceeds 2 mm. The drip test can, however, also be used to simulate the effect of a small amount of rain on instruments which might not normally be exposed to rain but which are protected against accidental short exposure to rainfall (e.g. camera systems). The low drip rates of conditioning method 72, degree of severity 01 or 02, are intended for exposure of this type.

The influence of rain on optical instruments is similar to that to which they are subjected to during exposure to moisture, as detailed in ISO 9022-2; the effects, however, are different. Thus, water in the form of drops, due to its surface tension, tends to penetrate into the instrument or components thereof much less than is the case with water vapour. Unlike exposure to water vapour, potential corrosion phenomena are not taken into account in the rain test.

The effect of the rain increases the higher the speed, the smaller the size of the drops, and the longer the exposure time. In order to facilitate the test measurement of the size of the drops and their constancy during the exposure time is not required by this part of ISO 9022. The shower head specified by this part of ISO 9022 produces rain with small drop sizes (<2 mm).

The degrees of severity correspond to conditions such as are encountered in a natural environment. Conditioning method 73 and degree of severity 01 simulate the maximum rain rate expected in Europe (i.e. 7mm/min for a duration of 5 min). This period is extended to 30 min as the rain rates measured in Europe during cloudburst range between 3 mm/min to 7 mm/min for a duration greater than 30 min. The maximum global rate reaches 20 mm/min for a duration of 5 min and is covered by degree of severity 02. The time of exposure to degree of severity 02 has also been fixed at 30 min, not only in order to tighten the test but also to partly simulate the rainfall of less intensity but considerably longer duration experienced, for example, in India, Myanmar, and Indonesia (600 mm within 24 h and 12 000 mm within one year).

The rain rate required for conditioning method 74 is less than that specified for conditioning method 73. However, due to the strong wind causing sprays and eddies when the rain impinges on the specimen, the stress acting on the latter is more severe during exposure to conditioning method 74 than to conditioning method 73.

A.2 Arrangement of shower heads in conditioning methods 73 and 74

[Figure A.1](#) and [Figure A.2](#) show a recommended arrangement of the shower heads for the rain test.

The arrangement shown in [Figure A.2](#) is intended for testing strongly fissured specimens. The shower head in the centre of [Figure A.1](#) and [Figure A.2](#) can be switched on separately from those in the corners and those in the centre of the sides. The shower heads and the supply pipes should be made of a corrosion-resistant material. The water is first cleaned by the connection of an appropriate filter. The required rain rate can be constantly adjusted within the admissible limiting deviations by the use of a booster pump with a pressure control valve and a back-up supply, and a flow-meter. Any lime or sediment should

be removed from the jet plates of the shower heads immediately after use and when dry, they should be stored separately.

Dimensions in metres

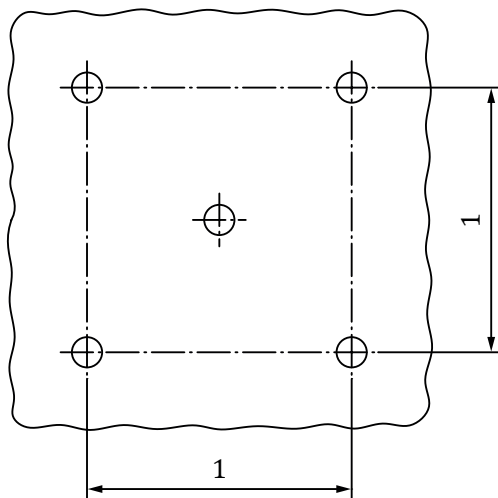

Figure A.1 — Top view of arrangement of one, four, or five shower heads

Dimensions in metres

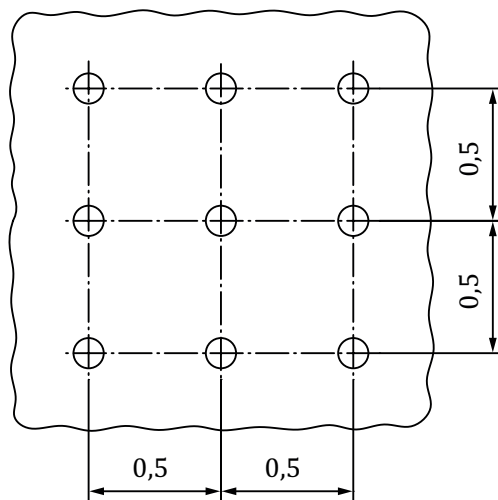
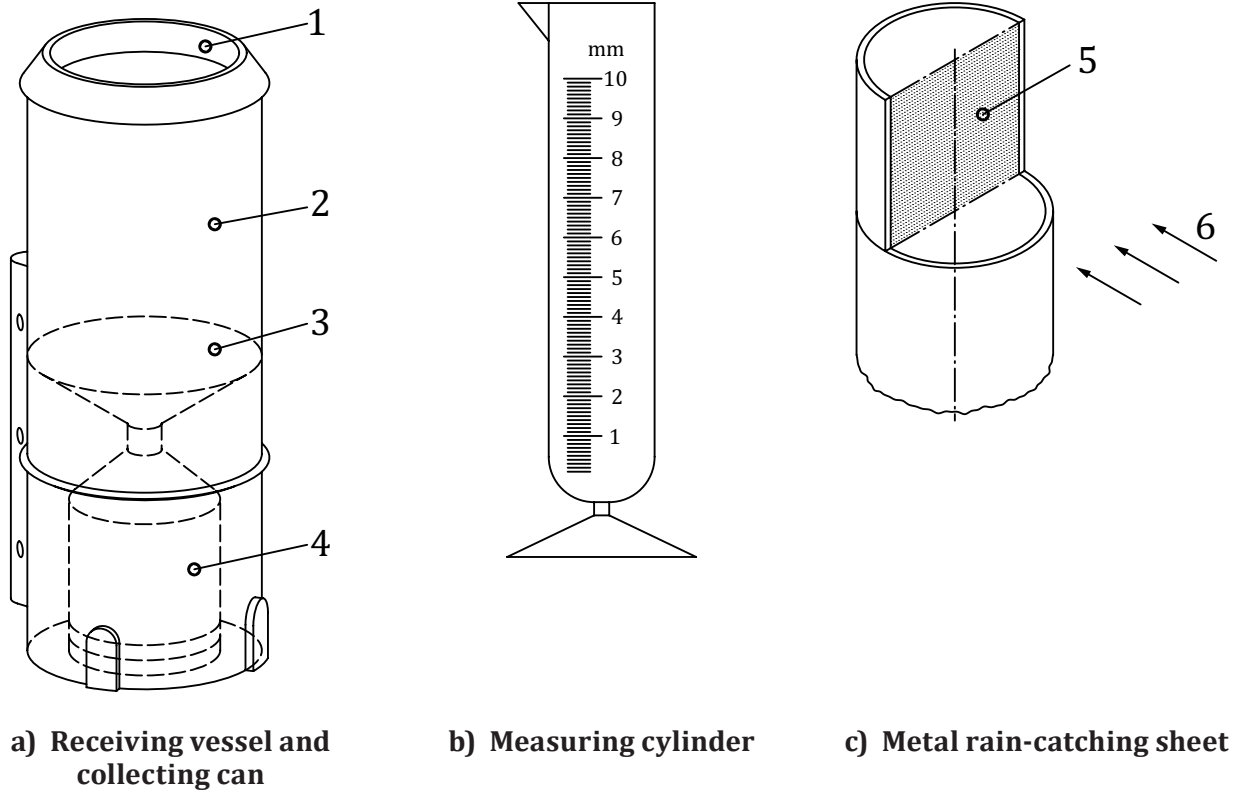

Figure A.2 — Top view of arrangement of nine shower heads

A.3 Hellmann rain gauge for measurement of the rain rate or drip rate

The gauge consists of receiving vessel (typically 200 cm² receiving aperture), collecting can, and corresponding measuring cylinder graduated in mm. For measurement of the rate of driving rain, a rain-catching sheet of same collecting area as the receiving vessel is inserted. See [Figure A.3](#) for a schematic representation. An example of suitable product available commercially is the “Rain gauge according

to Hellmann” supplied by Wilh. LAMBRECHT GmbH - Meteorological Instruments- Germany - www.lambrecht.net ¹⁾.



Key

- 1 receiving aperture
- 2 receiving vessel
- 3 collecting funnel
- 4 collecting can
- 5 rain-catching sheet for measuring rate of driving rain, inserted in the Hellmann-type rain gauge
- 6 wind direction

Figure A.3 — Schematic of Hellmann rain gauge

1) “Rain gauge according to Hellmann” is an example of a suitable product available commercially. This information is given for the convenience of users of this International Standard and does not constitute an endorsement by ISO of this product.

