**Optics and photonics —
Environmental test methods —**

**Part 4:
Salt mist**

*Optique et photonique — Méthodes d'essais d'environnement —
Partie 4: Brouillard salin*





COPYRIGHT PROTECTED DOCUMENT

© ISO 2014

All rights reserved. Unless otherwise specified, no part of this publication may be reproduced or utilized otherwise in any form or by any means, electronic or mechanical, including photocopying, or posting on the internet or an intranet, without prior written permission. Permission can be requested from either ISO at the address below or ISO's member body in the country of the requester.

ISO copyright office
Case postale 56 • CH-1211 Geneva 20
Tel. + 41 22 749 01 11
Fax + 41 22 749 09 47
E-mail copyright@iso.org
Web www.iso.org

Published in Switzerland

Contents

	Page
Foreword	iv
Introduction	vi
1 Scope	1
2 Normative references	1
3 General information and test conditions	1
3.1 Limitations of testing.....	1
3.2 Specimens.....	2
3.3 Apparatus (see Figure 2).....	3
3.4 Reagents.....	5
3.5 Salt spray test conditions.....	5
3.6 Test interruption and opening of test chamber.....	6
4 Conditioning method 40: Salt mist	6
5 Procedure	6
5.1 General.....	6
5.2 Preconditioning (specimen preparation).....	6
5.3 Recovery.....	7
5.4 Evaluation.....	7
6 Environmental test code	7
7 Specification	7
Annex A (informative) Explanatory notes	8

Foreword

ISO (the International Organization for Standardization) is a worldwide federation of national standards bodies (ISO member bodies). The work of preparing International Standards is normally carried out through ISO technical committees. Each member body interested in a subject for which a technical committee has been established has the right to be represented on that committee. International organizations, governmental and non-governmental, in liaison with ISO, also take part in the work. ISO collaborates closely with the International Electrotechnical Commission (IEC) on all matters of electrotechnical standardization.

The procedures used to develop this document and those intended for its further maintenance are described in the ISO/IEC Directives, Part 1. In particular the different approval criteria needed for the different types of ISO documents should be noted. This document was drafted in accordance with the editorial rules of the ISO/IEC Directives, Part 2 (see www.iso.org/directives).

Attention is drawn to the possibility that some of the elements of this document may be the subject of patent rights. ISO shall not be held responsible for identifying any or all such patent rights. Details of any patent rights identified during the development of the document will be in the Introduction and/or on the ISO list of patent declarations received (see www.iso.org/patents).

Any trade name used in this document is information given for the convenience of users and does not constitute an endorsement.

For an explanation on the meaning of ISO specific terms and expressions related to conformity assessment, as well as information about ISO's adherence to the WTO principles in the Technical Barriers to Trade (TBT) see the following URL: [Foreword - Supplementary information](#)

The committee responsible for this document is ISO/TC 172, *Optics and photonics*, Subcommittee SC 1, *Fundamental standards*.

This third edition cancels and replaces the second edition (ISO 9022-4:2002), of which it constitutes a minor revision.

ISO 9022 consists of the following parts, under the general title *Optics and photonics — Environmental test methods*:

- *Part 1: Definitions, extent of testing*
- *Part 2: Cold, heat and humidity*
- *Part 3: Mechanical stress*
- *Part 4: Salt mist*
- *Part 6: Dust*
- *Part 7: Resistance to drip or rain*
- *Part 8: High pressure, low pressure, immersion*
- *Part 9: Solar radiation*
- *Part 11: Mould growth*
- *Part 12: Contamination*
- *Part 14: Dew, hoarfrost, ice*
- *Part 17: Combined contamination, solar radiation*
- *Part 20: Humid atmosphere containing sulfur dioxide or hydrogen sulfide*

- *Part 22: Combined cold, dry heat or temperature change with bump or random vibration*
- *Part 23: Low pressure combined with cold, ambient temperature and dry and damp heat*

Introduction

Optical instruments are affected during their use by a number of different environmental parameters which they are required to resist without significant reduction in performance and to remain within defined specifications.

The type and severity of these parameters depend on the conditions of use of the instrument (for example, in the laboratory or workshop) and on its geographical location. The environmental effects on optical instrument performance in the tropics and subtropics are totally different from those found when they are used in arctic regions. Individual parameters cause a variety of different and overlapping effects on instrument performance.

The manufacturer attempts to ensure, and the user naturally expects, that instruments will resist the likely rigours of their environment throughout their life. This expectation can be assessed by exposure of the instrument to a range of simulated environmental parameters under controlled laboratory conditions. The severity of these conditions is often increased to obtain meaningful results in a relatively short period of time.

In order to allow assessment and comparison of the response of optical instruments to appropriate environmental conditions, ISO 9022 contains details of a number of laboratory tests which reliably simulate a variety of different environments. The tests are based largely on IEC standards, modified where necessary to take into account features special to optical instruments.

It should be noted that, as a result of continuous progress in all fields, optical instruments are no longer only precision-engineered optical products, but, depending on their range of application, also contain additional assemblies from other fields. For this reason, the principal function of the instruments shall be assessed to determine which International Standard should be used for testing. If the optical function is of primary importance, then ISO 9022 is applicable, but if other functions take precedence, then the appropriate International Standard in the field concerned should be applied. Cases can arise where application of both ISO 9022 and other appropriate International Standards will be necessary.

Optics and photonics — Environmental test methods —

Part 4: Salt mist

1 Scope

This part of ISO 9022 specifies the methods relating to the environmental tests of optical instruments including additional assemblies from other fields (e.g. mechanical, chemical, and electronic devices), under equivalent conditions, for their ability to resist the influence of salt mist.

Exposure to salt mist mainly results in the corrosion of metals. Effects might also occur by way of clogging or binding of moving parts.

The purpose of the testing is to assess, as early as possible, the ability of the instrument, and particularly of the surfaces and protective coatings of the instrument, to resist the effects of a salt atmosphere.

Normally, representative samples or complete small units are used for testing. Complete large instruments or assemblies are only tested as specified in this part of ISO 9022 in exceptional cases.

2 Normative references

The following documents, in whole or in part, are normatively referenced in this document and are indispensable for its application. For dated references, only the edition cited applies. For undated references, the latest edition of the referenced document (including any amendments) applies.

ISO 9022-1, *Optics and photonics — Environmental test methods — Part 1: Definitions, extent of testing*

3 General information and test conditions

3.1 Limitations of testing

3.1.1 General

The aim of salt mist testing is unlikely to be achieved, unless the deficiencies and limitations of such testing as detailed in [3.1.2](#) and [3.1.3](#) are fully recognized.

3.1.2 Suitability

Salt mist testing is considered suitable for

- a) the assessment of the resistance of optical and other functional layers,
- b) the assessment of the anti-corrosion effect of metallic and non-metallic coatings, and
- c) the early detection of the unacceptability of material combinations.

3.1.3 Unsuitability

Salt mist tests as specified in this part of ISO 9022 shall not be performed in the following cases:

- a) as a general corrosion test, as no verified data are available showing that there is a direct relationship between salt mist corrosion and corrosion caused by other attacking corrosive media or environments;
- b) on separate components or assemblies that are used only in assembled configurations or any other configurations protected from corrosion;
- c) as a true duplication of natural marine environment.

NOTE Generally, the salt mist test is not reliable for comparing the corrosion resistance of different materials or the anticorrosive effect of coatings exposed to varying climatic conditions, nor is it suitable for predicting the service life of such materials or coatings. Some idea of the service life of different specimens of identical or closely related metals, or of different specimens of identical or comparable protective coating combinations, can be gained by the salt mist test provided that, by correlating field service test data with laboratory tests, such relationships can be demonstrated as exist in the case of aluminium alloys. Such correlation tests are essential if data are required on the accelerating effect (if any) of laboratory testing as compared to performance under natural service conditions.

3.2 Specimens

Specimens shall be made of the basic materials used for the instrument under test; coatings (finishing coatings, protective coatings, thin films on optical parts), if any, shall be of the same structure as those used for the instrument components and surfaces to be assessed.

Specimens for testing metallic and non-metallic coatings shall preferably be metal sheets (sample sheets) as shown in Figure 1. The coating under test shall completely cover the sample sheet, especially the outer edges and edges of holes. Where this is not feasible, exposed metal edges shall be protected by a means that does not affect the coating under test. Marking of the sample sheets shall not damage the coating to be tested (e. g. punch-marking shall be carried out prior to applying the coating).

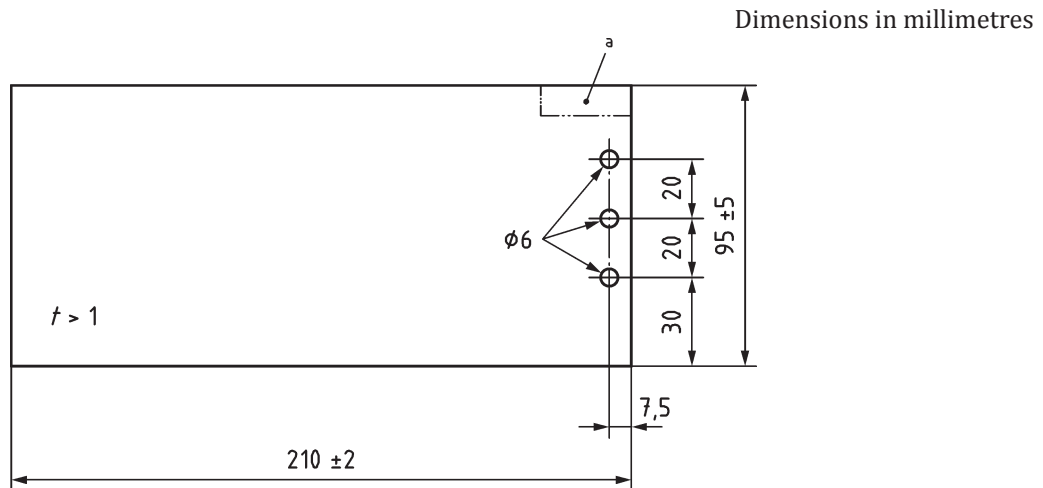

a Marking area (on the back).

Figure 1 — Sample sheet

Where the instruments or instrument components to be assessed are made of cast material, the use of specimens originating from the same batch shall be agreed upon and documented in the test report.

In the test of optical and other functional layers, specimens shall be used as test-pieces which consist of the same basic materials as the original components.

Complete large instruments and assemblies, or separate components that are used in assembled configurations only, shall not be tested in accordance with this part of ISO 9022, unless as an exception. If necessary, essential areas of such specimens and of specimens other than sample sheets (e. g. electrically insulated components, open assemblies) may be used for assessment by agreement between the parties concerned.

3.3 Apparatus (see [Figure 2](#))

The test apparatus essentially comprises of the components described below. All parts of the test apparatus that come into contact with the salt mist or the test solution shall be made of a material that will not affect the corrosiveness of the test solution or the salt mist.

3.3.1 Test chamber, used for salt mist tests including a heated exposure chamber providing pressure balance and measuring/controlling means to adjust and maintain the test temperature to $35\text{ °C} \pm 2\text{ °C}$ within the closed chamber. The test chamber shall have a volume of not less than 400 l; it shall be constructed so as to prevent condensate dripping from overhead and from the sidewalls onto the specimens. The dripping of condensate from overhead can be avoided by inclining the exposure chamber at least 30° to the horizontal.

Test solution, once atomized, shall not return into the salt solution reservoir.

The exposure zone is that part of the test chamber which is not covered by the cone-shaped spray, and where uniform distribution of the mist can be demonstrated in accordance with [3.5.2](#).

3.3.2 Atomizing nozzles, made of polymethylmethacrylate or polyvinylchloride and having an opening of 1 mm in diameter. Their dispersion angle is approximately 30° and they are operated at a positive pressure of between 70 kPa and 140 kPa, and a suction level of 200 mm to 500 mm. Salt mist has been proven to be best produced by self-priming compressed air nozzles without a regulating or quick-cleaning needle. It is useful to provide a means for measuring and controlling the flow of fluid (see [Figure 2](#)); serving to adjust and control the amount of salt solution to be atomized so that the condensate collected per hour in the exposure chamber is kept within the acceptable tolerances specified in [3.5.2](#).

The spray shall not impinge upon the specimens. It may therefore be necessary to direct the spray against one of the chamber walls (see [Figure 2](#), example 2) or, if the nozzle is installed at the bottom of the chamber, to provide a guide tube (see [Figure 2](#), example 1).

The number and location of the atomizing nozzles shall be selected so that the requirements for the available exposure space as specified in [3.5.2](#) are met.

Other types of nozzles may be used provided that the materials of which they are made of do not affect the corrosiveness of the salt mist and that the salt mist produced by such nozzles meets the requirements specified in [3.5.2](#).

3.3.3 Levelling receptacle and supply line, for the salt solution to be atomized, designated, and constructed so that the suction level remains constant throughout the duration of the test.

3.3.4 Airline including oil and solid matter trap, and humidifier, designed and constructed so that the compressed air remains saturated with water at the required temperature throughout the duration of the test. A pressure gauge for measuring the air pressure at the nozzle shall be installed in the airline running from the humidifier to the exposure chamber.

3.3.5 Racks, permitting the arrangement of the specimens within the available exposure space so that they do not come into contact with each other.

Major surfaces of representative samples and, if possible, of assemblies shall be inclined at least 60° to the horizontal.

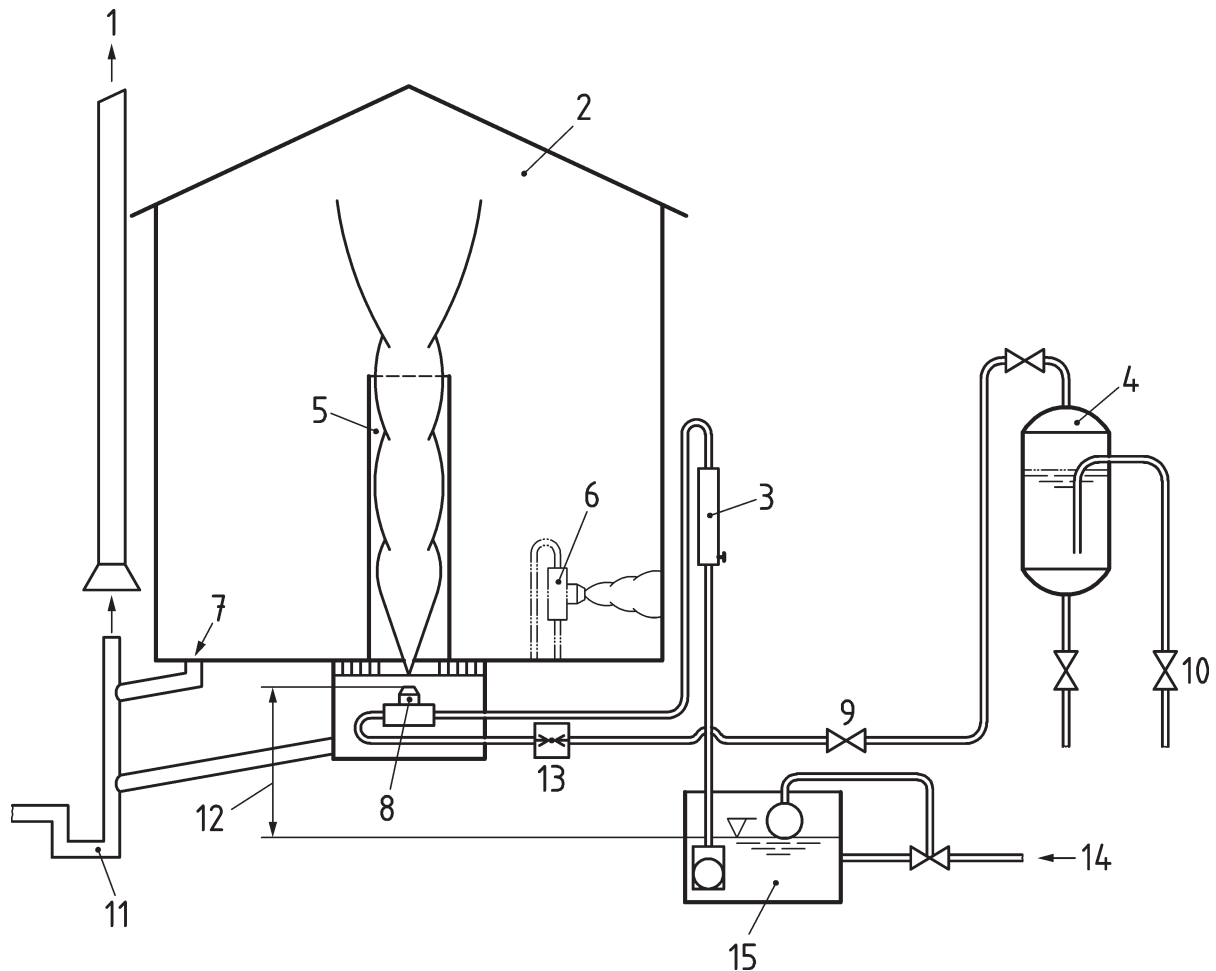

Key

- 1 chamber ventilation
- 2 exposure chamber
- 3 fluid flow measuring and controlling device
- 4 humidifier
- 5 example 1: guide tube around atomizing nozzle
- 6 example 2: atomizing nozzle directed against chamber wall
- 7 pressure balance
- 8 atomizing nozzle
- 9 air inlet control valve
- 10 compressed air, free from oil and solid matter
- 11 siphon
- 12 suction level 200 mm to 500 mm
- 13 pressure gauge
- 14 filtered sodium chloride solution
- 15 sodium chloride solution reservoir and liquid-level controller

Figure 2 — Schematic representation of test apparatus, showing two different locations of atomizing nozzle

Sample sheets shall be placed on edge at an angle of 60° to 75° to the horizontal. Unless otherwise specified in the relevant specification, instruments and, if required, assemblies shall be installed in the exposure chamber in their operating position.

The specimens shall be arranged in the exposure chamber in such a manner that they do not overlap or come into contact with each other and that condensate cannot drip down upon them. Care shall be taken to prevent contact corrosion (e. g. electrolytic action or crevice corrosion) where the specimens come into contact with the supporting racks.

The supporting racks for the specimens shall be made of one of the following materials: glass, polypropylene, non-plasticized PVC (polyvinyl chloride), PA 66 (polyamide), PA 6, etc.

Supporting devices shall not damage the surface coatings or release agents which change the surface of the test piece or react with the coatings.

3.4 Reagents

3.4.1 Test solution, 5 % mass fraction aqueous solution of sodium chloride obtained by dissolving $50 \text{ g} \pm 10 \text{ g}$ of sodium chloride (NaCl), and containing not more than 1 % total impurities in 950 g of water at ambient temperature. The pH of the sodium chloride solution shall be adjusted so that the pH of the collected condensate will be in the range of 6,5 to 7,2, measured at a temperature of $25 \text{ }^\circ\text{C} \pm 2 \text{ }^\circ\text{C}$. Only chemically pure dilute hydrochloric acid or sodium hydroxide solution shall be used to adjust the pH. The pH shall be measured either electrometrically using a glass electrode at a temperature of $25 \text{ }^\circ\text{C} \pm 2 \text{ }^\circ\text{C}$, or colourimetrically using bromothymol blue as indicator (see [Annex A](#)). The concentration of sodium chloride in the collected condensate shall be $50 \text{ g/l} \pm 10 \text{ g/l}$.

The water used to prepare the test solution shall be distilled or demineralized (completely softened); its electrical conductivity at a temperature of $25 \text{ }^\circ\text{C} \pm 2 \text{ }^\circ\text{C}$ shall not exceed $20 \text{ } \mu\text{S/cm}$ and the proportion of solid matter shall not be more than 100 ppm.

The test solution shall be filtered before use to remove any solid matter which might block the aperture of the spraying device.

The sprayed solution shall not be able to return to the sodium chloride solution reservoir, nor shall it be reused.

3.4.2 Compressed air, used for atomizing the test solution, at a positive pressure of 70 kPa to 140 kPa, and free from dirt, oil, and other impurities. It shall therefore be passed through standard oil and liquid separators, followed by a ceramic compressed air cleaner, so that at least 99,5 % of the impurities are removed.

1 m^3 of purified air shall contain less than 0,2 mg of oil and dust particles of less than $5 \text{ } \mu\text{m}$ in size.

The purified air shall then be saturated with water (using a humidifier operating on demineralized water) at such a temperature that the air reaches approximately $35 \text{ }^\circ\text{C}$ after expansion (see [Annex A](#)).

It is necessary to saturate the compressed air with water in order to prevent an increase of the sodium chloride concentration in the atomized solution.

3.5 Salt spray test conditions

3.5.1 Temperature

During testing, the temperature in the exposure zone of the closed test chamber shall be $35 \text{ }^\circ\text{C} \pm 2 \text{ }^\circ\text{C}$. If it becomes necessary to open the test chamber, the temperature may be allowed to fall by a few degrees. It shall be measured sufficiently in order to record all temperature changes, if possible.

It is recommended to record the temperature curve by means of the thermograph and to ensure a uniform temperature distribution by providing adequate thermal insulation of the test chamber.

3.5.2 Salt mist

The amount of salt solution to be atomized per unit of time within the exposure chamber shall be such that over a period of not less than 16 h, a mean of 1,5 ml ± 0,5 ml of solution per hour for each 80 cm² of horizontal collecting area is collected in a receptacle placed in the bottom of the test chamber.

As for the atomizing nozzles (3.3.2), it has been proven useful to adjust, only by means of the external flow measuring and controlling device, the amount of salt solution to be atomized at a given constant positive pressure of the compressed air and a constant suction level.

Other methods of adjusting the amount of salt solutions to be atomized are acceptable, provided that they ensure uniform distribution of the salt mist within the exposure zone and do not impair the deposition characteristics of the salt mist. In order to permit verification of the uniformity of salt mist distribution within the exposure zone, a minimum of two collecting receptacles shall be placed in the bottom of the chamber near the racks supporting the specimens, one near a nozzle and one distant from the nozzles. The receptacles shall be arranged in such a manner that they cannot collect condensate dripping down from the chamber ceiling or walls, or from the racks or specimens. Receptacles suitable for collecting the atomized solution are, for instance, glass or plastics funnels of 10 cm in diameter (corresponding to a collecting area of approximately 78,5 cm²), fitted into a glass or plastic measuring cylinder by means of a plug.

3.6 Test interruption and opening of test chamber

Salt mist tests shall be conducted as uninterrupted trials. The salt solution shall be continuously atomized throughout the exposure period. Atomizing shall not be interrupted during the exposure period unless it is necessary to open the test chamber for the purpose of removing specimens for assessment or to replace them.

If intermediate inspections are required, care shall be taken to prevent the specimens from becoming dry; wet them, if appropriate, using test solution (3.4.1) at room temperature. Under no circumstances shall intermediate inspections take more than 30 min for each 24 h of test duration.

4 Conditioning method 40: Salt mist

See [Table 1](#).

Table 1 — Degrees of severity for conditioning method 40: Salt mist

Degree of severity	01	02	03	04	05	06	07
Exposure time	2 h	4 h	8 h	16 h	2 d	4 d	8 d
State of operation	1 or 2						

5 Procedure

5.1 General

The test shall be conducted in accordance with the requirements of the relevant specification and with ISO 9022-1.

5.2 Preconditioning (specimen preparation)

If not specified in the relevant specification, the surface of the specimen shall be properly cleaned prior to exposure. To this end, only such neutral cleaning agents shall be used as that do not leave a film on or attack the surface of the specimen. After cleaning, the specimen shall be restored to service condition, e.g. by the application of protective grease.

5.3 Recovery

After exposure, the specimen shall be gently washed. First, under running water, using a soft brush where appropriate and then in demineralized water, to remove salt deposits. The water used shall not be warmer than 38 °C. After having been allowed to drain, the specimens shall be conditioned for 1 h at a temperature of 40 °C ± 3 °C in a heating cabinet provided with air circulation.

5.4 Evaluation

The test is considered successful if the tolerances for function and physical appearance as specified in the relevant specification are met; slight changes in colour and/or brightness and corrosion of protective coatings are acceptable. Corrosion of the substrate is not acceptable.

6 Environmental test code

The environmental test code shall be as defined in ISO 9022-1, giving a reference to ISO 9022 and the codes for the conditioning method chosen, the degree of severity, and the state of operation.

EXAMPLE The environmental test of optical instruments for resistance to salt mist, conditioning method 40, degree of severity 02, state of operation 1, is identified as:

Environmental test ISO 9022-40-02-1

7 Specification

The relevant specification shall contain the following details:

- a) environmental test code;
- b) number of specimens;
- c) type and dimensions of the specimens or sample sheets;
- d) arrangement and position of the specimens in the exposure chamber, if other than specified in [3.3](#);
- e) preconditioning of specimen (see [5.2](#));
- f) type and scope of initial test;
- g) determination of the period of operation for state of operation 2;
- h) type and scope of intermediate test for state of operation 2 and information as detailed in [3.3](#);
- i) recovery, if other than specified in [5.3](#);
- j) type and scope of final test;
- k) criteria for evaluation (see [5.4](#));
- l) type and scope of test report.

Annex A (informative)

Explanatory notes

A.1 Self-priming compressed air nozzles (3.3.2)

The operating method given for the self-priming compressed air nozzles requires a reduction of the nozzle flow on the liquid side, with the result that only a part of the nozzle spray flow possible at constant air pressure and at the constant suction level prescribed will be reached.

When using composite atomizing nozzles, it has been proven useful to have the nozzle set at maximum suction flow at an air pressure of approximately 100 kPa by the supplier or, alternatively, to perform the setting oneself and then mark and fix this position before mounting. This facilitates the resetting of the movable nozzle caps to maximum suction power if the nozzles have to be removed and taken apart for cleaning.

Experience has shown that, for a test chamber with a volume of up to approximately 10 m³ and a surface area of approximately 5 m² (in rectangular surface area with an aspect ratio of between 1:1 and 1:5), one atomizing nozzle as described in 3.3.2 will suffice.

A.2 pH of sodium chloride solution (3.4.1)

When using water containing carbon dioxide for preparing the sodium chloride solution, care is to be taken when setting the pH value, as carbon dioxide escapes when atomizing the solution at 35 °C, and the recollected solution, therefore, has a higher pH value than the solution prior to atomizing. For this reason, a sodium chloride solution made with water containing carbon dioxide is to be set to a pH value under 6,5 at a temperature of 25 °C ± 2 °C, so that the recollected solution will have a pH between 6,5 and 7,2. To test if the pH of the solution before atomizing has been correctly set, remove 50 ml of the solution, boil lightly for approximately 30 s and cool to 25 °C ± 2 °C, then measure the pH value immediately. If the pH value measured lies between 6,5 and 7,2, experience has shown that the pH value of the recollected spray will also lie in this range.

A.3 Air humidifier temperature (3.4.2)

On leaving the atomizing nozzle, the pressure of the compressed air decreases to the pressure of the surrounding atmosphere and cools down on the process. To ensure a spray temperature of 35 °C, the temperature of the compressed air saturated with water is to be greater than 35 °C. Table A.1 shows empirical temperature values (air humidifier temperature), which the compressed air saturated with water is to have in relation to the positive pressure in order to have a temperature of approximately 35 °C after meeting the atmosphere.

Table A.1 — Empirical values of air humidifier temperature

Compressed air positive pressure kPa	Air humidifier temperature throughout salt mist test °C
70	45
84	46
98	47
112	48

Table A.1 (continued)

Compressed air positive pressure kPa	Air humidifier temperature throughout salt mist test °C
126	49
140	50

